

# TOUGH SERIES ROWER

No more compromising on your workouts. Whether you're competing live against your peers, trying to out-row world-class athletes in "Pros vs Joes" or being chased by sharks, Aviron's Tough Series Rower will put an end to boring workouts and have you coming back for more.

SPECIFICATIONS

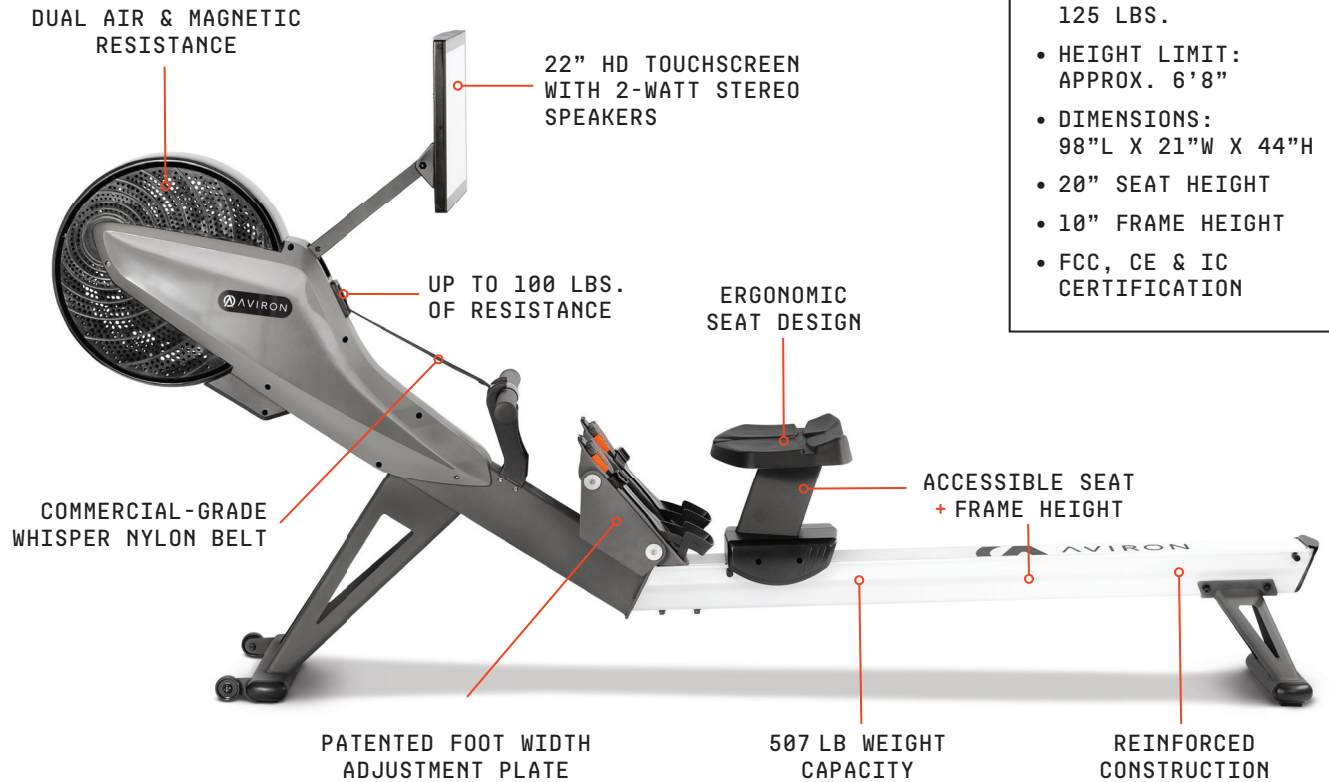

- ROWER WEIGHT: 125 LBS.
- HEIGHT LIMIT: APPROX. 6'8"
- DIMENSIONS: 98"L X 21"W X 44"H
- 20" SEAT HEIGHT
- 10" FRAME HEIGHT
- FCC, CE & IC CERTIFICATION

## THE AVIRON DIFFERENCE



### SHORT WORKOUTS

Never miss another workout with a variety of short, effective LIIT and HIIT programs and games aimed at keeping you fit while saving you time.



### COMFORT AND ACCESSIBILITY

Elevated seating, low frame height, patented foot width adjustment, and ergonomic seating make the Tough Series the ultimate in performance, comfort and accessibility.



### BEST-IN-CLASS RESISTANCE

With up to 100 lbs. of resistance, incorporating strength training into your routine is easy. Tone and shape your body while improving your cardio endurance all on one machine.



### UNMATCHED CONTENT VARIETY

End boring workouts with 500+ programs across 8 diverse categories from games, live competition, virtual rowing to coached programs and more.

# THE FUTURE OF FITNESS ENTERTAINMENT

Aviron uses habit-forming psychology and game design to keep you motivated, excited and coming back for more. Whether live racing against other members, streaming your favorite content, out-rowing world-class athletes or fending off swarms of pirate attacks, Aviron's vast library of programs and games will end boring workouts.

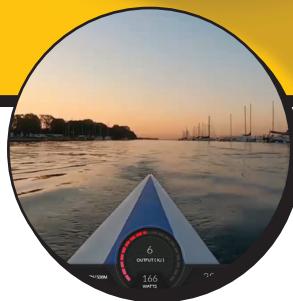

## 8 WAYS TO WORKOUT WITH AVIRON



### GAMES

Battle waves of robots, fend-off treasure hungry pirates or test your endurance with the old school inspired Row Breaker.



### POWER PLAY

Combine the visual excitement of games with guided programs as you earn points in a race towards your fitness goals.



### LIVE COMPETITION

Compete live against friends, family or community members for the leaderboard.



### VIRTUAL ROWING

Warm up or cool down as you row through the world's most scenic destinations.



### STREAMING

Track your stats while streaming your favorite shows with Netflix, Disney+, Hulu, Prime Video and YouTube.



### GUIDED PROGRAMS

Reach your fitness goals with full body workouts that take you on-and-off and push yourself to new limits.



### COACHED PROGRAMS

Form, strength training, mobility, and more with trainer and rowing coach Austin Hendrikson AKA Training Tall.



### PROS VS JOES

Put yourself to the ultimate test and race against a selection of pro athletes and Olympians.